

MODELS | BestMove 400
| BestMove 450

**PRODUCT
FEATURES**

ASSEMBLY

**OPERATING
INSTRUCTIONS**

WARRANTY

OWNER'S MANUAL
AND INSTRUCTION GUIDE



**BestMove 450 shown*

BEFORE USE:



Ensure the product has been assembled according to the instructions in this manual.

All operators should have received or read and understood the instructions for safe and proper operation of the BestMove standing transfer aid.

Thank you for choosing Bestcare!

To better serve you, please record
the following information:

Supplier Name: _____

Telephone: _____

Serial #: _____

Date of Purchase: _____

INSPECT YOUR MERCHANDISE

Upon receipt of your Bestcare Lift, verify that all merchandise is complete and free from any shipping damage. Refuse delivery if the packaging appears to be badly damaged. If the merchandise is received damaged or is missing components, contact the shipping company immediately and file a claim.

For further assistance, contact your local dealer or Bestcare LLC at the following:

Bestcare LLC
5885 Shiloh Rd., Suite 104
Alpharetta, GA 30005
678-679-6690 / 1-877-822-9033
www.bestcarellc.com
© Bestcare LLC

SAFETY INSTRUCTIONS



- **FAILURE** to use this device according to instructions may cause serious injury.
- **NEVER** attempt to transfer a patient or resident whose weight exceeds the indicated maximum capacity for this device or any accessory.
- **NEVER** leave a patient unattended during transfer
- **DO NOT** use without complete understanding of safe and correct operation
- **DO NOT** use for the purpose of transportation over long distances.
- **DO NOT** use for the purpose of seating over long extended periods of time..

DEFINITIONS

In this manual the user refers to the patient or resident and may be used interchangeably at different times Caregiver refers to the operator or person who is assisting with the transfer.

Symbols used in this manual and their meanings:



Warning! Failure to heed this warning may result in damage to the product or serious injury to the operator and/or user.



Important instructions follow. Read and understand the instructions in the manual before using the product.



Note! Important information concerning the product and/or its correct and proper usage follows.

PRODUCT FEATURES

DESCRIPTION & APPLICATIONS

The BestMove series are offerings from Bestcare that represent a class of medical devices collectively referred to as standing transfer aids. The BestMove standing transfer aid is positioned between a traditional walker or wheelchair and the common electric stand assist patient lift. The BestMove is a transfer assist unit which keeps the user actively engaged in the process. Transfer functions of all types are quick and require minimal caregiver assistance. Each unit is equipped with a crossbar where users can grasp and pull their self up into a standing position using their own strength. The padded split seats swing out allowing the user to stand up and board the unit. The caregiver then flips the split seats back into place to form a secure and comfortable seat for the user to sit on for the remainder of the transfer.

A patient or resident who qualifies to use the BestMove must have enough leg and lower body strength to stand up and remain in the standing/sitting position. Adequate arm strength is required if the patient must use crossbar. Users who satisfy these criteria and have difficulty walking or present a potential for falling down will find the BestMove a useful and safe transfer device. For patients who lack these requirements, a sit-to-stand lift such as the electric powered BestStand patient lift is preferred and recommended.

The BestMove standing transfer aid is suitable for the following types of transfers:

- Bed to Chair/Wheelchair
- Bed/Chair/Wheelchair to commode
- Room to Room

SPECIFICATIONS

& OPTIONS

**PRODUCT
FEATURES**

	BestMove 400	BestMove 450
Maximum Capacity	400 Lb / 182 Kg	450 Lb / 205 Kg
Minimum Base Width	16.2"	26.8
Maximum Base Width	25.5"	37"*
Open Base Width	N/A	37"*
Closed Base Width	N/A	26.7"
Base opens	No	Yes
Overall Height	43"	43.3"
Base Height	4.5"	4.5"
Minimum Seat Height	26.7"	26.7"**
Seat Width	20"	20"
Overall Length	32"	35.4"
Unit Weight	57 Lb	71 Lb
Knee Pads / Shin Guards	Yes	Yes
Optional Support Strap	Yes	Yes
Optional Seat Locks	Yes	Yes
Upgrade Base to 450 Lb	Yes	N/A

**Measured to the outside of each base leg with the base legs in the widest open position*

***Measured from the ground to the bottom of the seat*

ASSEMBLY

i Prior to assembly, unpack all parts from the shipping carton and check for any missing parts. Contact your dealer immediately if a part is missing.

Parts List

1. Cross Bar x 2
2. Right Side Arm
3. Left Side Arm
4. Side Support Arm x 2
5. Knee Pad Support Bar
6. Knee Pad x 2
7. Seat x 2

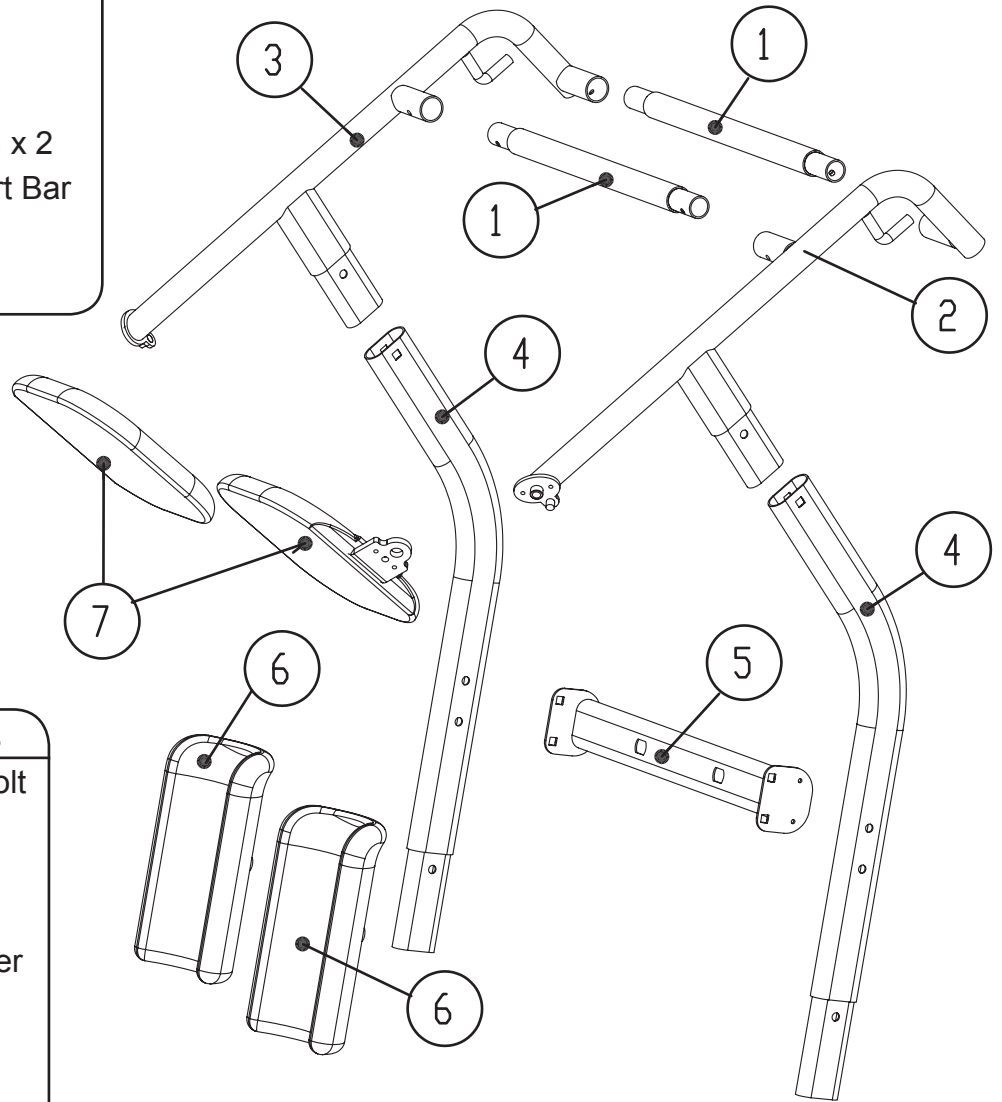

Tools & Fasteners

- | | | |
|----|-----|---------------|
| A1 | 8x | Carriage bolt |
| A2 | 2x | Hex bolt |
| A3 | 4x | Hex screw |
| A4 | 10x | Washer |
| A5 | 10x | Lock washer |
| A6 | 8x | Lock nut |
| A7 | 2x | Plastic cap |
| T1 | 1x | Wrench |
| T2 | 1x | Allen key |

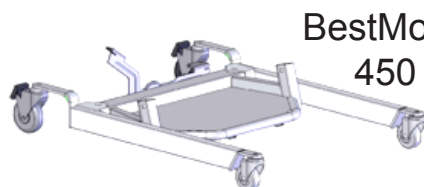

BestMove
450



BestMove
400

Factory assembled base with foot plate and castors

STEP BY STEP ASSEMBLY

1

Place the base assembly on the floor and lock casters in place for ease of assembly.

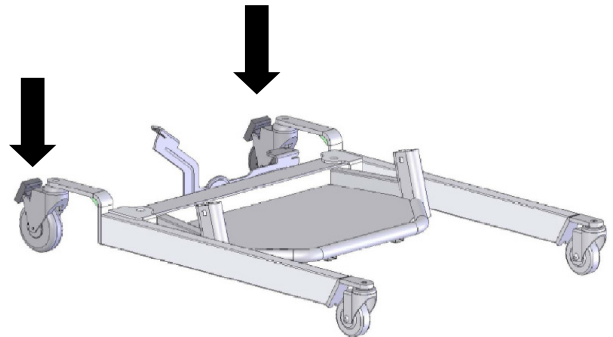

Insert the kneepads into the support bar and secure them in place with bolts and washers (**A2 + A5 + A4**) as indicated below.

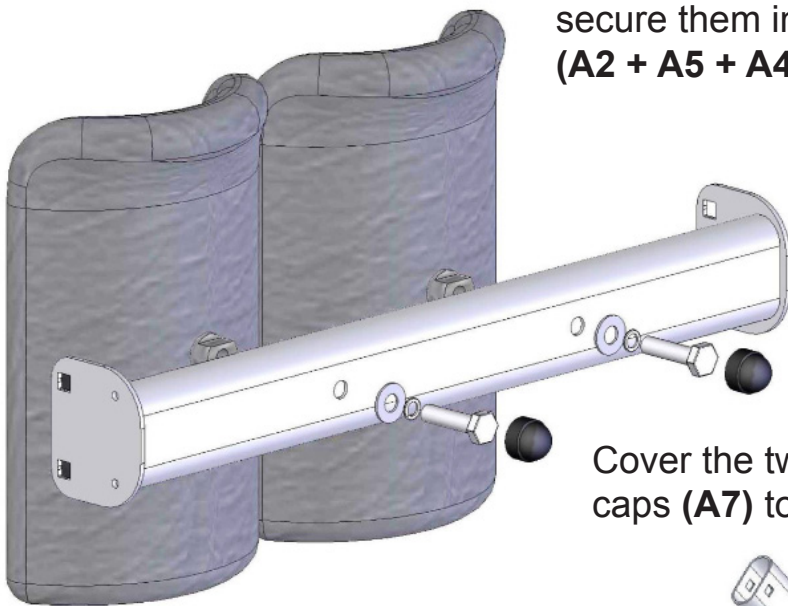

2

Cover the two bolt heads with black plastic caps (**A7**) to complete kneepad assembly.

ASSEMBLY

Install the kneepad assembly between the two side support arms as shown. Fasten in place with four carriage bolts, nuts and washers.

3

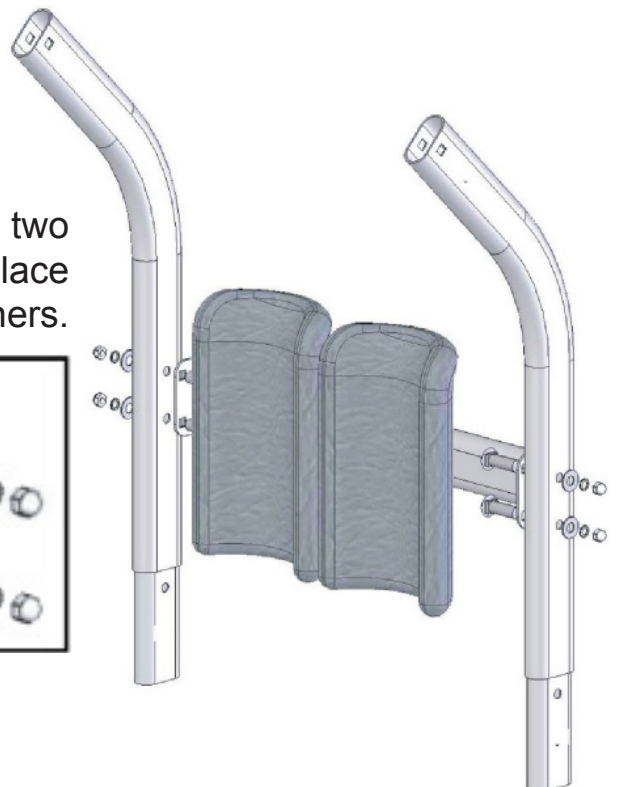
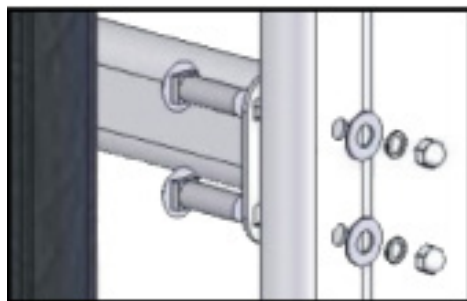

Insert the two cross bars into the holes on the seat and handle bar support units.

Line up the small holes on the underside of the tubes with the holes in the support units.

Use the 4 hex screws (A3) with Allen key (T2) to tighten the completed assembly

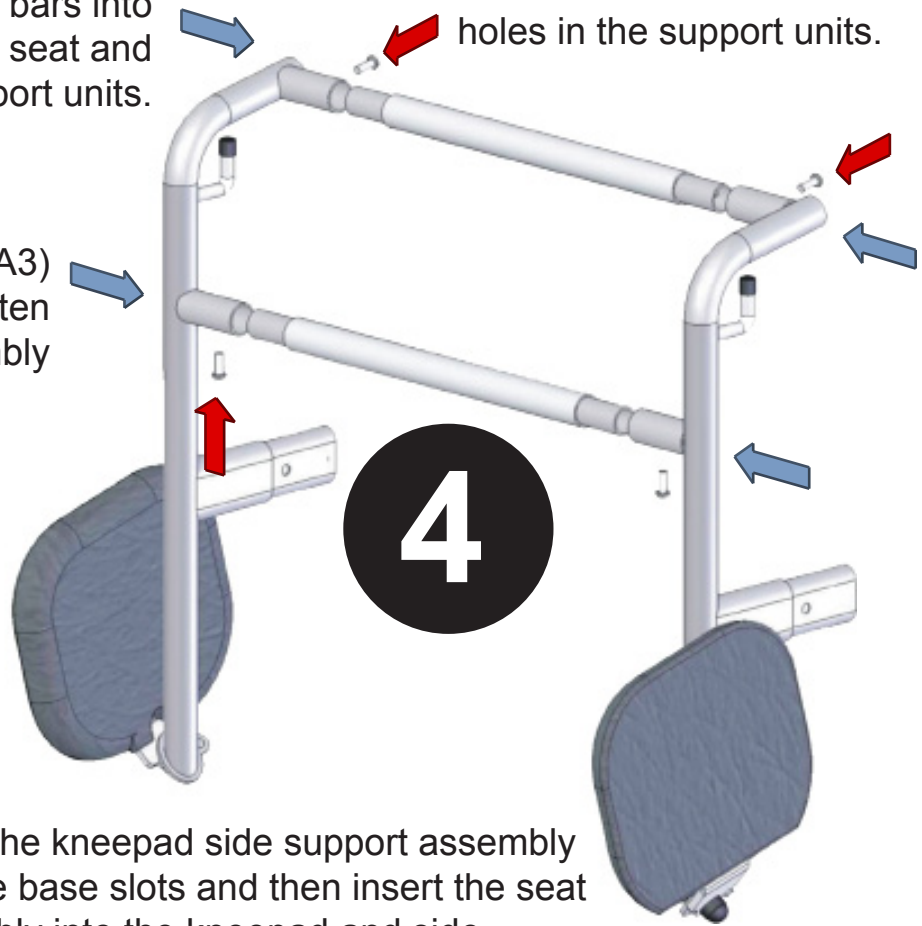

5

Insert the kneepad side support assembly into the base slots and then insert the seat assembly into the kneepad and side support assembly.



6

Use the remaining 4 carriage bolt assemblies to securely fasten the two sub assemblies to the base unit. All of the square shoulders of the bolts should be on the inside and the washers and lock nuts on the outside. **(A1 + A4 +A5 +A6)**

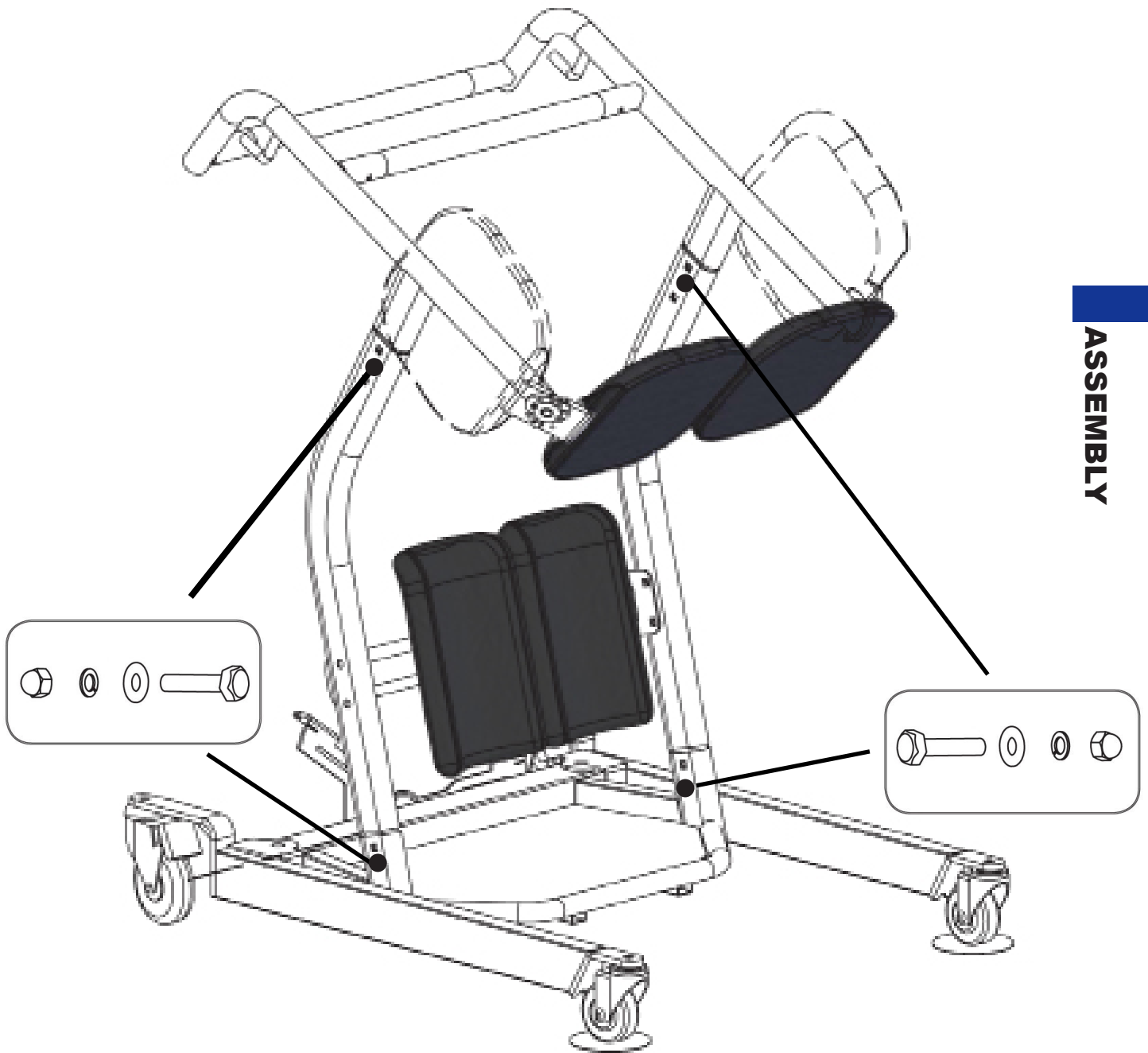

OPERATING INSTRUCTIONS



Double check all assemblies for tightness and read operating instructions carefully prior to use.



SEAT USAGE INSTRUCTIONS

The two black molded seat units can be rotated upwards to allow for patient loading. Once the patient is in an upward standing position the split seats must be lowered down to form a complete two-sided seat. Always make sure each of the two seat components are properly lowered forming a complete seat prior to having the patient sit down.

STEP 1

Raise the two split seat units up and parallel to the side of the BestMove as shown below.

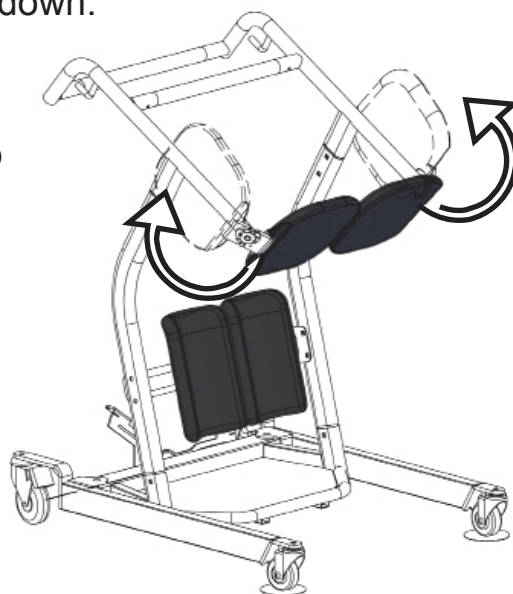

STEP 2

Have the patient positioned at the edge of the surface and move the standing transfer aid in front of the patient so that their feet are firmly on the platform and knees/shins are in contact with the two cupped knee/shin pads as shown below. The Bestmove 450 allows access around wider obstacles such as recliners. The base of the BestMove 450 opens by stepping the foot pedal.



STEP 3

Lock the casters by stepping on the caster clip and pushing down as shown below.

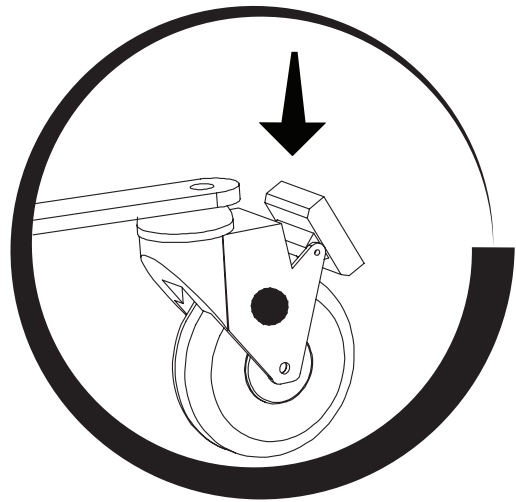

STEP 4

Have the patient grasp the cross bar closest to them and using their own strength pull themselves up into a standing position firmly on the platform as shown.



STEP 5

Lower both of the split seat units down into position to form a complete seat as shown.



**OPERATING
INSTRUCTIONS**

STEP 6

Have the patient lower themselves down onto the seat while keeping their knees/shins in the knee/shin pads and while still holding the cross bar with both hands as shown.



STEP 7

Unlock the casters and place both hands on the cross bar furthest from the patient and move the standing transfer aid to the new surface. Make sure the patient is secure and in proper position as described in Step 6 above prior and during transfer as shown below.



MAINTENANCE & INSPECTION

- The BestMove Standing Transfer Aid is a manual unit and therefore requires minimal maintenance on an ongoing basis. However to insure safety and proper use the following steps should be taken on a monthly basis.
- Check all bolt/nut assemblies to make sure they are tight and no wear and tear is evident. Replace and tighten any worn assemblies prior to using the BestMove.
- Check the two seat assemblies to make sure they are not worn or damaged and that the bolts are tight. Replace any worn or damaged seat components before using the BestMove.
- Check the casters to make sure they are in working order and are secured firmly to the BestMove. Replace any worn or damaged casters prior to using the BestMove.

ACCESSORIES

The BestMove Standing Transfer Aid is designed to fully support a seated patient for transport. For patients requiring some upper body support or additional security a safety belt may be used. Either the SL-SA669 Standard or SL-SA669B Extra Large slings are designed to work with the Bestmove. See the pictures below for the use of these slings:

Support Strap



Seat Lock

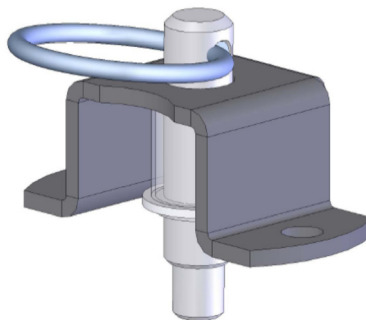

**BESTCARE LLC
WARRANTY AND RETURN GOODS POLICY**

WARRANTY POLICY:

Bestcare LLC offers a limited warranty on all patient lifts, slings and accessories to be free of defects in workmanship and product performance. This warranty is extended only to the original purchaser/user and is therefore non transferrable. Any warranty claims must be submitted through an authorized dealer or distributor that sold the original product with proper proof of sale and serial number supplied. Prior authorization from Bestcare LLC is required for any warranty replacement and we reserve the right to replace parts and or accessories in lieu of sending complete new patient lifts. Dealers and distributors will be billed for any advance warranty replacement items shipped and credited at 100% only when the defective items have been returned to Bestcare LLC and proven defective. Product returned without a Bestcare LLC return authorization will be refused. Returns received 30 days after the issuance of a return authorization will also be refused as the authorization will have expired. The final disposition of warranty claims will be subject to our inspection of the returned items. Bestcare LLC has the right to determine valid claims based on the individual circumstances of each claim. Warranty claims will be denied should evidence of the following be determined:

- Misuse of product , modification of product or failure to maintain as per the owner's manual
- Serial number removed or defaced
- Normal wear and tear

Bestcare LLC warrants the following products and components for the time period specified:

- Lift frames and spreader bar: 3 years
- Actuator: 2 years
- Parts including casters, control box, PCB, pendant, charger: 2 years
- Batteries: 1 year
- Weigh Scale: 2 years
- Spryte Stand Aid all components: 2 years
- Hydraulic pumps: 1 year
- Reusable slings: 6 months

Bestcare LLC Single Patient Slings are designed for limited use with one patient and may not be washed. Bestcare will replace any disposable slings found to have a manufacturing defect. Normal wear and tear will not be covered under warranty.

RETURN GOODS POLICY:

Bestcare LLC will allow goods to be returned only with prior authorization and a valid RA number issued by the RA co-coordinator. RA's will only be provided for items invoiced within 30 days of the initial RA request. All returns must be received at Bestcare LLC within 30 days or the RA will expire. The returning package must be clearly marked with the RA number or the shipment will not be received or any credit issued. When a part is returned to Bestcare LLC for warranty inspection a \$50 service charge will apply if the part is not defective. Returns are subject to a minimum re-stocking fee of 15% or more depending on the condition of the returned items. Where an item was ordered incorrectly according to your purchase order or the customer no longer wants the item(s) returning freight is the responsibility of the dealer/customer not Bestcare LLC.

Patient lifts may not be returned unless the following has occurred:

- The wrong lift was shipped in error by Bestcare LLC
- The lift is heavily damaged or defective out of the box

Please note that lifts being returned must be in the original carton and all parts and components included with the return. Failure to comply with this requirement will incur higher re-stocking fees or a rejection of the return. Slings, parts and accessories may only be returned if they have not been used. There are no exceptions to this provision. Bestcare LLC reserves the right to issue credit amounts based on strict adherence to this policy.

Bestcare L.L.C.

Bestcare LLC
5885 Shiloh Road Suite 104
Alpharetta, GA 30005
tel. 678-679-6690
free 1-877-822-9033